

DOWNLIGHT IP54 SD

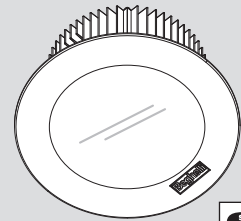

ta: -20÷40°C

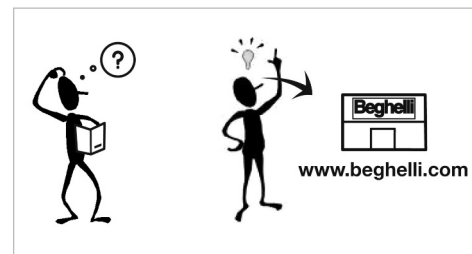

www.beghelli.com

www.beghelli.com
 BEGHELLI S.p.A. - Via Mozzeghine 13/15 - località Monteveglio 40053 Valsamoggia (BO) ITALY - Tel. +39 051 9660411 - Fax +39 051 9660444 - N° Verde 800 626626

** Driver in dotazione IP20
 ** Driver supplied IP20

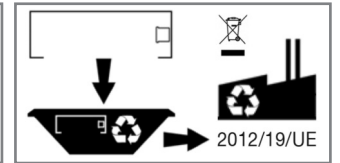
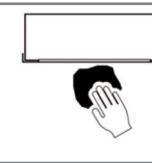

334.901.900 B

A

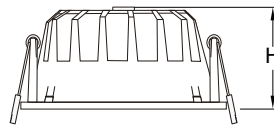
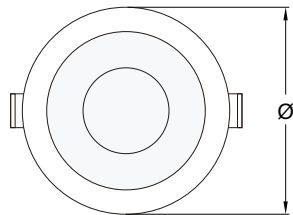

W	Ø lamp (mm)	H lamp (mm)	T (Ø mm)
10	102	68	Ø 90
15	140	68	Ø 120
25	180	90	Ø 150
35	230	120	Ø 200

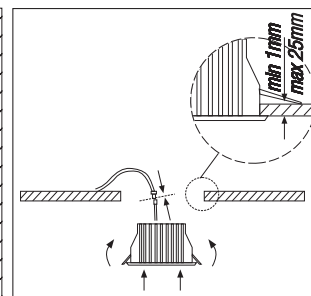
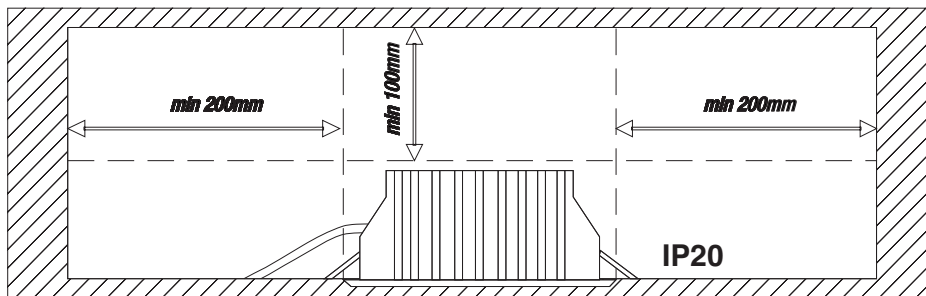

IP20
 IP54

B

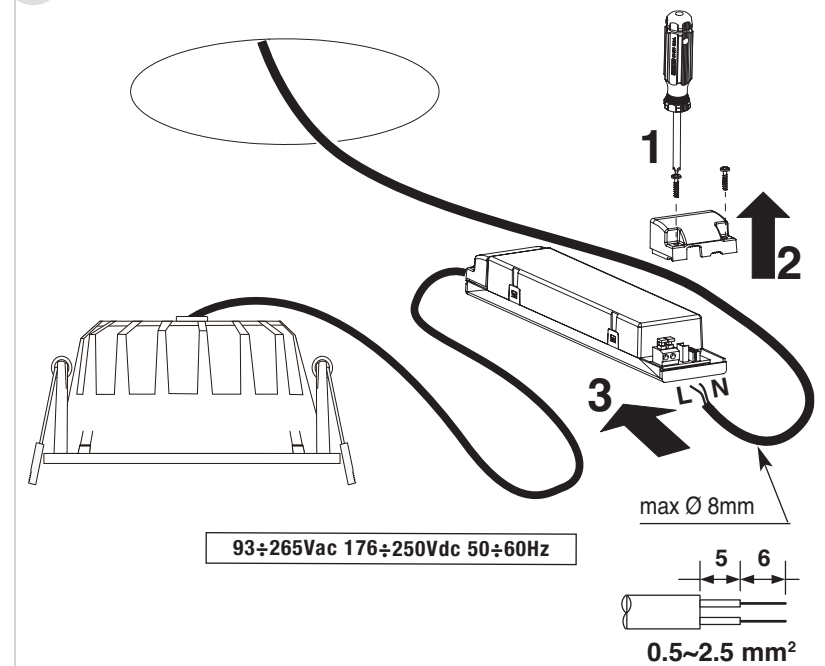

UTILIZZO DEL MODULO RADIO DOMOTICO (COD. 15022) (C)

Per il funzionamento consultare anche i manuali della Centrale Domotica (cod. 20102) o del Trasmettitore radio Domotico (cod. 20104) e del Modulo radio Domotico (cod. 15022).

E' necessario posizionare:

- 1 - l'etichetta PICCOLA sullo schema dell'impianto per consentirne la rintracciabilità (fig. C1);
 - 2 - l'etichetta GRANDE o MEDIA sulla lampada che contiene il Modulo radio, in modo che sia ancora visibile quando installata (fig. C2).
- Fissare il radio circuito lontano da superfici che possano provocare schermature radio (superfici metalliche...).

AVVERTENZE - GARANZIA

- Questo apparecchio dovrà essere destinato solo all'uso per il quale è stato costruito. Ogni altro uso è da considerarsi improprio e pericoloso.
- La sorgente LED è di tipo non sostituibile. Per eventuali riparazioni rivolgersi ad un centro di assistenza tecnica autorizzato e richiedere l'utilizzo di ricambi originali. Il mancato rispetto di quanto sopra può compromettere la sicurezza dell'apparecchio.
- Per le modalità di intervento in garanzia contattare il Numero Verde 800 626626 o il Rivenditore Autorizzato.

C

MONTAGGIO MODULI RADIO, DALI E 1-10V - INSTALLATION MODULES RADIO, DALI AND 1-10V - MONTAGE VON FUNKMODULEN, DALI UND 1-10V

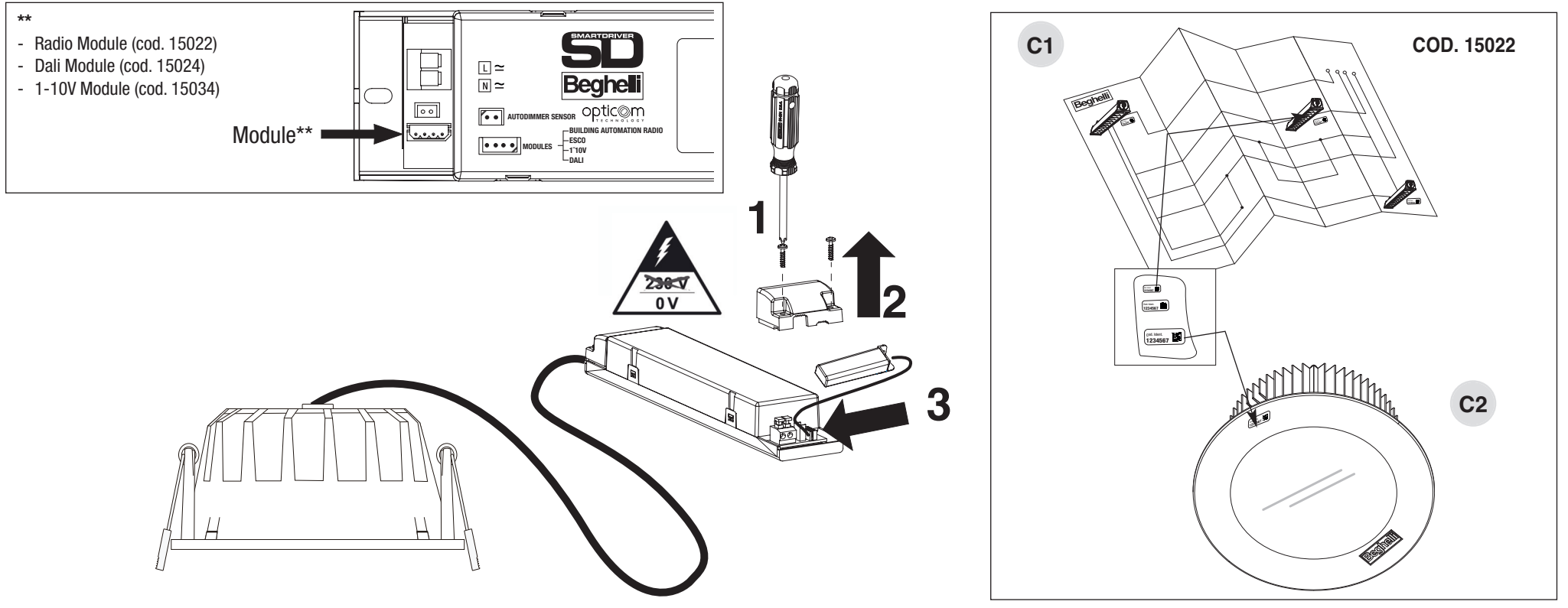

USING THE RADIO MODULE (COD. 15022) (C)

For the functioning please refer to the instruction manuals either of the Central device (code 20102) or of the Radio Transmitter (code 20104) and the Radio Module (cod. 15022).

It is important to stick these labels as follows:

- 1 - the little label should be positioned on the plant drawing for an easy tracing of the luminaire (picture C1);
- 2 - the medium and large labels should be positioned on the luminaire where the radio device is mounted in a way to be visible when the luminaire is installed (picture C2).

Install the radio circuit far from surfaces capable of creating radio jamming (metal surfaces, etc).

WARNINGS - GUARANTEE

- This device shall be used exclusively for the purpose for which it has been designed. Any other use is considered improper and therefore dangerous.
- LED source is not replaceable. Contact an authorised technical service centre for any repairs possibly required use only original spare parts. The lacked respect of the above conditions may compromise the safety of the device.
- For details regarding warranty services, contact an authorized dealer.

VERSION MIT FUNK-MODUL (ART.NR.: 15022) (C)

Die Funktion ist in den Bedienungsanleitungen des Controller LogicaFM (Art.Nr.: 20102), des Funk-Interface (Art.Nr.: 20104) des Funk-Modul (Art.Nr.: 15022) erläutert.

Die Aufkleber sollten wie folgt verwendet werden:

- 1 - Den kleinen Aufkleber auf dem Gebäudeplan platziert werden (Bild C1).
- 2 - Den mittleren und großen Aufkleber auf der Leuchte nahe dem Funk-Modul erkennbar platzieren (Bild C2).

WARNHINWEISE - GARANTIE

- Das Gerät darf ausschließlich für den Zweck, für den es hergestellt wurde, verwendet werden. Jede davon abweichende Verwendung wird als nicht zweckentsprechend und somit als gefährlich angesehen.
- Die LED-Quelle ist nicht austauschbar. Wenden Sie sich bei Reparatureingriffen an eine zugelassene technische Servicestelle und fordern Sie Originalersatzteile an. Das Nichteinhalten vorstehender Bestimmungen kann die Gerätesicherheit gefährden.
- Zu Fragen der Garantiebedingungen kontaktieren Sie uns unter +49 (0)206497010 oder einen autorisierten Händler.