

# BS100 SD Bluetooth®

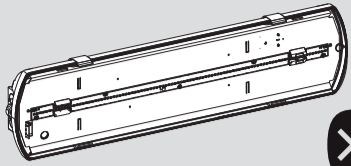

Per approfondimenti e aggiornamenti inquadra il codice QR sul prodotto  
For further information and updates, scan the QR code on the product



Ta: -20÷40°C  
IK05-07\*

230V-50Hz  
IP65



# Beghelli

www.beghelli.com  
BEGHELLI S.p.A. - Via Mozzeghine 13/15 - località Monteveglio 40053 Valsamoggia (BO) ITALY - Tel. +39 051 9660411 - Fax +39 051 9660444 - N° Verde 800 626626

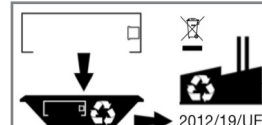
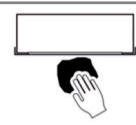
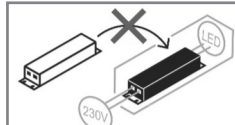

334.902.252 A

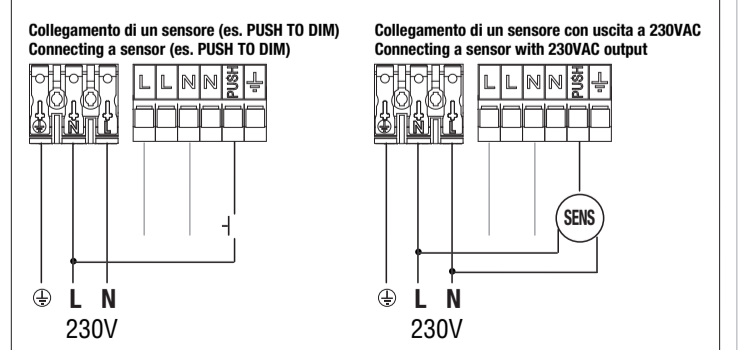
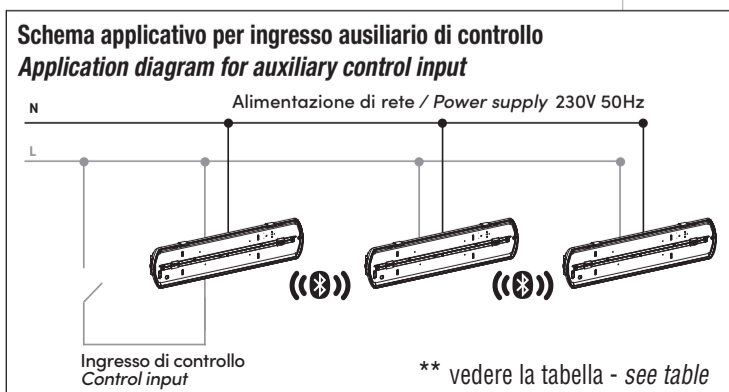
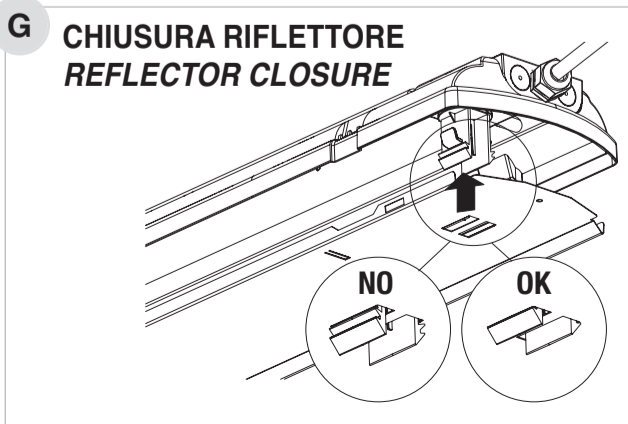
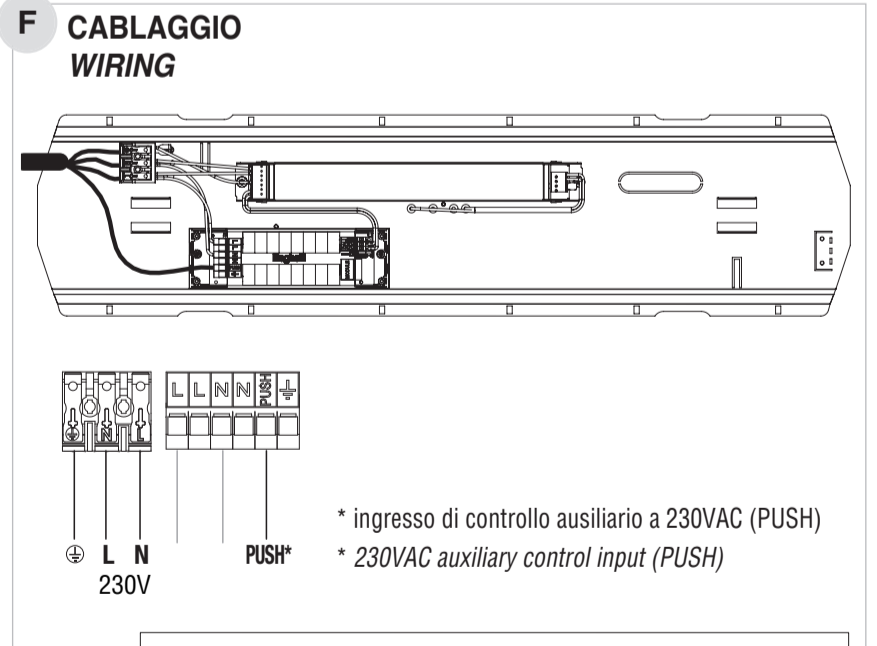
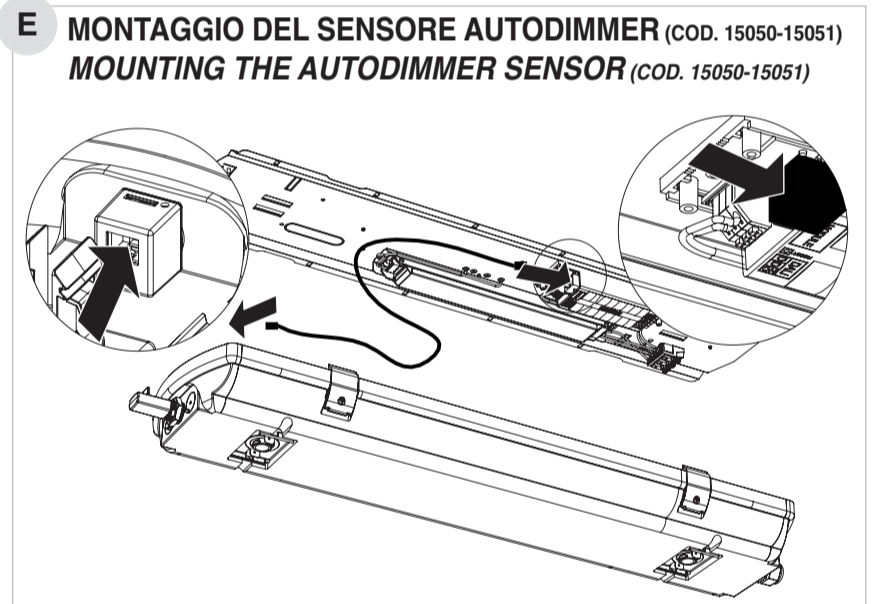
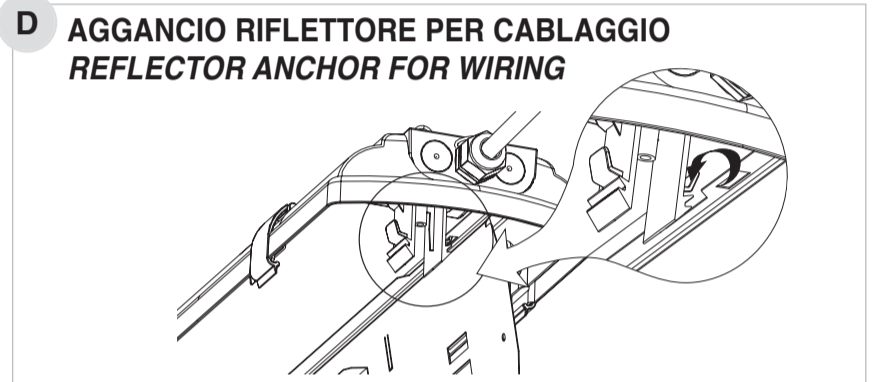
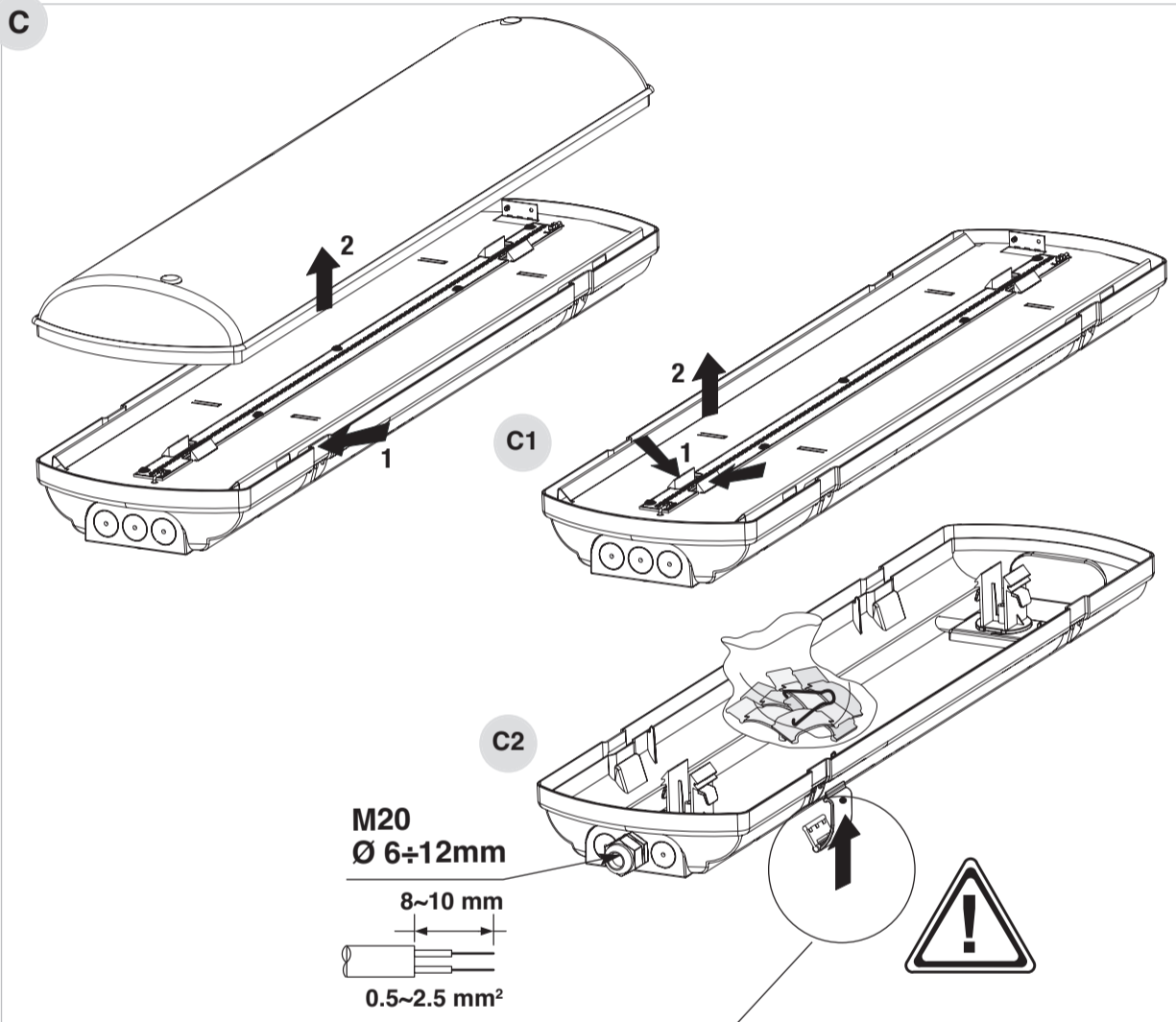
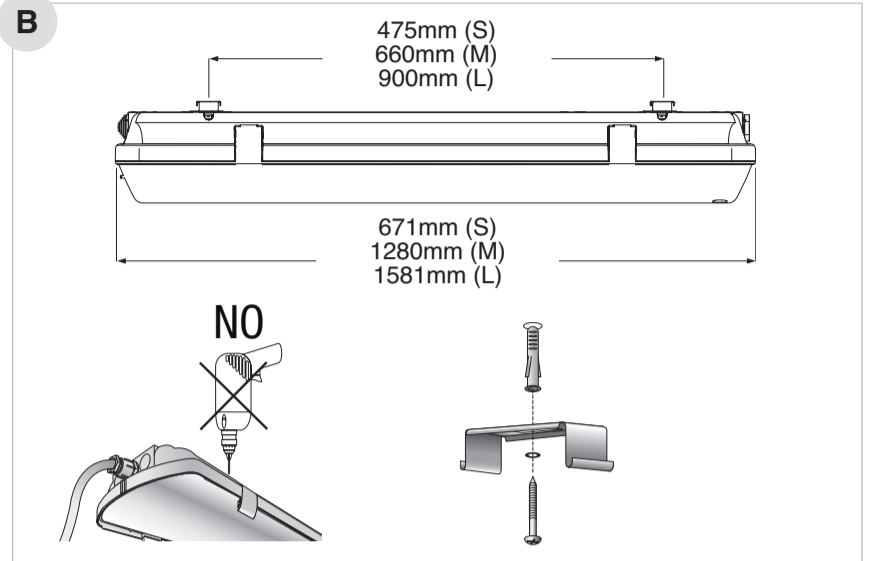
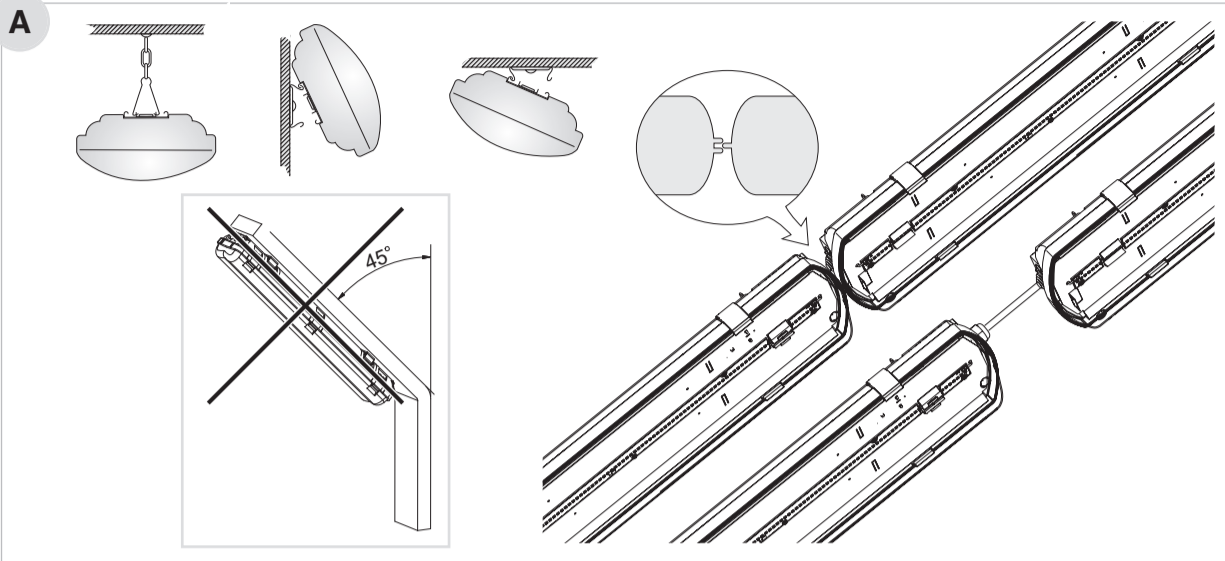

H

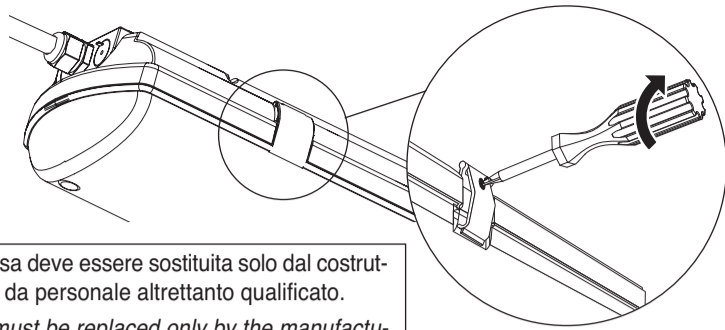

Apparecchio in cui la sorgente luminosa deve essere sostituita solo dal costruttore, dal suo servizio di assistenza o da personale altrettanto qualificato.

Luminaire in which the light source must be replaced only by the manufacturer, by its assistance service or by equally qualified personnel.

I

## SMONTAGGIO UNINSTALL

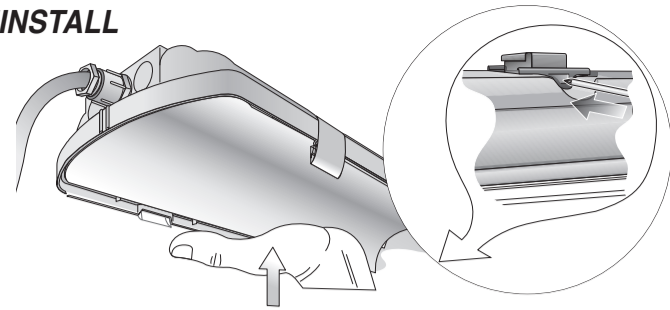

### Settaggio con App B.connect - Setting with App B.connect

Aprire App B.connect (scaricabile su App Store e Google Play).

#### APPARECCHIO NON INSERITO IN UN IMPIANTO:

Dopo la prima accensione l'apparecchio ha un finestra di comunicazione Bluetooth® di 7 giorni (168 ore), periodo di tempo in cui è possibile configurare l'apparecchio senza possedere credenziali di accesso.

Trascorso questo tempo non è più possibile comunicare con l'apparecchio per chi non è in possesso delle credenziali di accesso (password dell'impianto realizzato). Se l'apparecchio non è stato ancora configurato dopo 24 giorni, spegnendo e riaccendendo l'apparecchio la comunicazione Bluetooth® si riattiva per 2 ore consentendone la configurazione.

#### APPARECCHIO INSERITO IN UN IMPIANTO:

Gli apparecchi sono bloccati da password e la comunicazione rimane sempre aperta per i proprietari dell'impianto.

Open App B.connect (available for download on the App Store and Google Play).

#### EQUIPMENT NOT INCLUDED IN A SYSTEM:

After first switching on the device has a Bluetooth® communication window of 7 days (168 hours), period of time in which it is possible to configure the device without having access credentials.

After this time it is no longer possible to communicate with the device for anyone who does not have the access credentials (password of the system created). If the device has not yet been configured after 24 days, by turning the device off and on again, Bluetooth® communication is reactivated for 2 hours allowing configuration.

#### EQUIPMENT INCLUDED IN A SYSTEM:

The devices are locked by password and communication always remains open for the owners of the system.

Configurazione/comando Configuration/command	Singola lampada senza impianto Single lamp without plant	Con impianto - With plant		
		NO Gateway NO Centrale	+ Gateway (cod. 15064 - 15074 - 15174)	+ Centrale (cod. 21102)
Sistema di comunicazione Communication system	Bluetooth integrato nell'apparecchio Bluetooth integrated into the device	Bluetooth integrato nell'apparecchio Bluetooth integrated into the device	Bluetooth integrato nell'apparecchio Bluetooth integrated into the device	Modulo Autodimmer Radio cod. 15051 Autodimmer Radio module cod. 15051
Configurazione lampada Lamp configuration	Solo impostazione potenza massima con App Maximum power setting only with App	Funzionalità avanzate configurabili da App Advanced features configurable from the App	Con App o NuBe With App or NuBe	Con App, NuBe o SD Manager With App, NuBe or SD Manager
Ingresso di controllo: Control Input:	Solo funzione "Push to Dim" preconfigurata su singola lampada Pre-configured "Push to Dim" function only on a single lamp	Varie funzioni configurabili via App (una per gruppo**) - Many functions configurable via App (one per group**) Sensore di presenza configurabile (occupancy, vacancy, corridor function) - Configurable presence sensor (occupancy, vacancy, corridor function) Pulsante configurabile (Push to Dim, On/Off, Pulsante scene, Pulsante temporizzato...) - Configurable button (Push to Dim, On/Off, Scene button, Timed button...)		
Sensore Autodimmer Autodimmer sensor	Opzionale (cod. 15050) su ogni singola lampada Optional (code 15050) on each individual lamp	Opzionale (cod. 15050) uno per gruppo** Optional (code 15050) one per group**	Opzionale (cod. 15050) uno per gruppo** Optional (code 15050) one per group**	Opzionale (cod. 15051) uno per gruppo** Optional (code 15051) one per group**
Impostazioni di sicurezza Security settings	Bluetooth disattivato dopo 2 ore Bluetooth disabled after 2 hours	Bluetooth sempre attivo e ogni apparecchio protetto con password; comunicazioni crittografate Bluetooth always active and each device protected with a password; encrypted communications		
Controllo remoto via internet Remote control via internet			OK	OK
Monitoraggio energetico / diagnostica Energy monitoring / diagnostics		Singola lampada da App Single lamp from App	Impianto da App e Cloud App and Cloud plant	Impianto da App, Cloud, tool locale Plant from App, Cloud, local tool
Scenari Scenarios			OK	OK con funzionalità avanzate OK with advanced features
Numero di lampade gestibili Number of manageable lamps		64 lampade per 250 zone 64 lamps for 250 zones	64 lampade per gateway (un gateway per zona) 64 lamps per gateway (one gateway per zone)	996 lampade per centrale 996 lamps per control unit
Gestione Lampade Lamp Management		Locale gruppi di lampade con App connessa Local groups of lamps with connected App	Locale e cloud Local and cloud	Locale e cloud Local and cloud

## MONTAGGIO INVERTER EMERGENZA (OPZIONALE) EMERGENCY KIT MOUNTING (OPTIONAL)

+ COD. 19367 - 19371 - 19398 - 19399



Temperatura di esercizio 0÷30°C

Operating temperature 0÷30°C

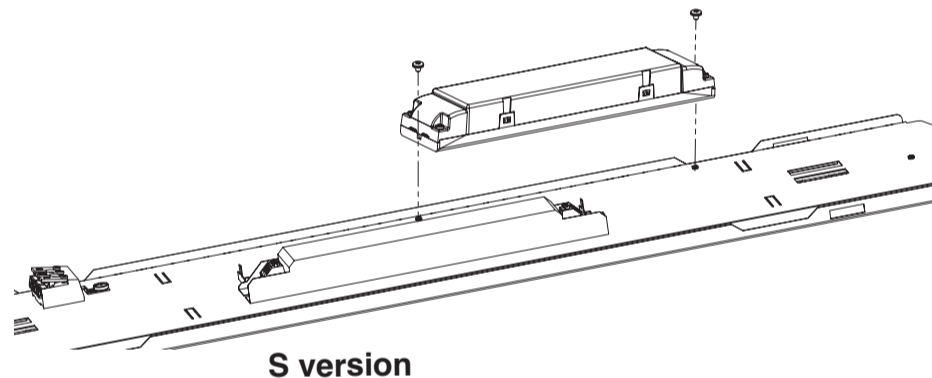
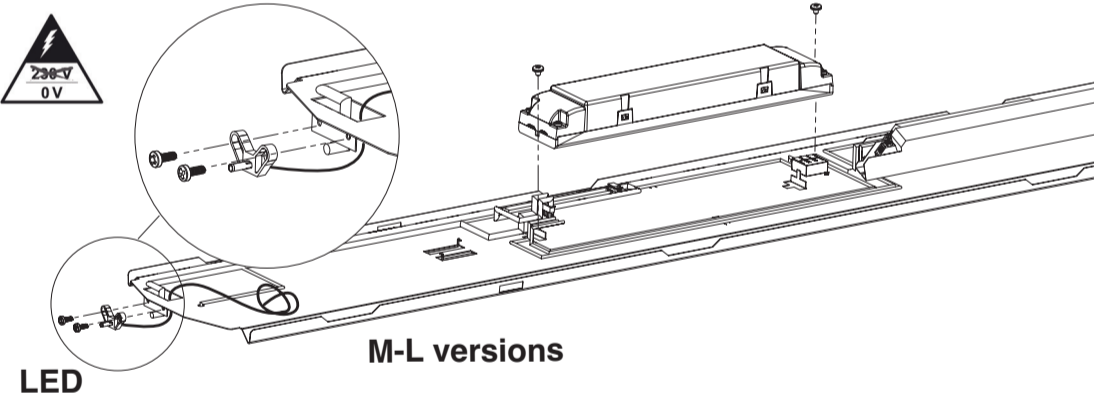

S version

#### UTILIZZO DEL SENSORE AUTODIMMER (COD. 15050-15051) (E)

**Attenzione:** mantenere i sensori lontani da sorgenti luminose esterne e possibilmente allineati. Con impianto fare attenzione alla scelta dell'apparecchio su cui montate il sensore.

#### CARATTERISTICHE TECNICHE RADIO

- Banda di frequenza: 2,4GHz-2,4835GHz
- Potenza RF: <100mW e.i.r.p.

#### AVVERTENZE - GARANZIA

- Questo apparecchio dovrà essere destinato solo all'uso per il quale è stato costruito. Ogni altro uso è da considerarsi improprio e pericoloso.
- Per eventuali riparazioni rivolgersi ad un centro di assistenza tecnica autorizzato e richiedere l'utilizzo di ricambi originali. Il mancato rispetto di quanto sopra può compromettere la sicurezza dell'apparecchio.
- Questo prodotto contiene una sorgente luminosa di classe di efficienza energetica D.
- \* **Attenzione:** scossa elettrica

Beghelli S.p.A. dichiara che il dispositivo ricetrasmittitore radio è conforme alla direttiva 2014/53/UE. Il testo completo della Dichiarazione di Conformità UE del dispositivo è disponibile al seguente indirizzo internet:

[www.beghelli.it/it/area-tecnica/strumenti/download](http://www.beghelli.it/it/area-tecnica/strumenti/download)

Il suddetto dispositivo può essere utilizzato in regime di "libero uso".

#### USING THE AUTODIMMER SENSOR (COD. 15050-15051) (E)

**Important:** keep the sensors away from any possibly aligned external light sources. With a system, pay attention to the choice of the device on which you mount the sensor.

#### RADIO TECHNICAL CHARACTERISTICS

- Frequency band: 2.4GHz-2.4835GHz
- RF power: <100mW e.i.r.p.

#### WARNINGS - GUARANTEE

- The light source contained in this luminaire shall only be replaced by the manufacturer or his service agent or a similar qualified person.
- This device shall be used exclusively for the purpose for which it has been designed. Any other use is considered improper and therefore dangerous.
- Contact an authorised technical service centre for any repairs possibly required use only original spare parts. The lacked respect of the above conditions may compromise the safety of the device.
- This product contains a light source of energy efficiency class D.
- \* **Caution:** electric shock

Beghelli S.p.A. declares that the radio transceiver is in conformity with Directive 2014/53/UE. The full text of the EU Declaration of Conformity of the device is available at the following Internet address: [www.beghelli.it](http://www.beghelli.it)

The aforementioned device can be used under "free use".

#### VERWENDUNG DES AUTODIMM-MODUL (ART.NR.: 15050-15051) (E)

**Achtung:** Den Sensor nicht in der Nähe von externen Lichtquellen platzieren. Achten Sie bei einem System auf die Wahl des Gerätes, an dem Sie den Sensor montieren.

#### FUNKTECHNISCHE EIGENSCHAFTEN

- Frequenzband: 2,4GHz-2,4835GHz
- RF-Leistung: <100mW e.i.r.p.

#### WARNUNG - GARANTIE

- Die Lichtquelle in dieser Leuchte enthalten darf nur durch den Hersteller oder seinen Kundendienst oder eine ähnlich qualifizierte Person ersetzt werden.
- Das Gerät ist ausschließlich für den Zweck, für den es hergestellt wurde, zu verwenden. Jede davon abweichende Verwendung wird als nicht zweckentsprechend und somit als gefährlich angesehen.
- Für eventuelle Reparaturen kann ein autorisiertes Service-Center kontaktiert werden, um original-Ersatzteile anzufordern. Das Nichteinhalten der oben genannten Bestimmungen kann die Gerätesicherheit gefährden.
- Dieses Produkt enthält eine Lichtquelle der Energieeffizienzklasse D.
- \* **Achtung:** Es besteht die Gefahr des elektrischen Schlags

Beghelli S.p.A. erklärt, dass der Funk-Sender/Empfänger der Richtlinie 2014/53/EU entspricht. Der komplette Text der EU-Konformitätserklärung kann unter folgender Internetadresse eingesehen werden: [www.beghelli.it](http://www.beghelli.it)

Die oben genannte Vorrichtung ist zur "freien Verwendung" vorgesehen.

#### POUŽITÍ SENZORU AUTODIMMER (KÓD 15050-15051) (E)

**Upozornění:** udržte senzory dále od ostatních externích světelných zdrojů. U systému věnujte pozornost výběru zařízení, na které senzor namontujete.

#### RADIOTECHNICKÁ CHARAKTERISTIKA

- Frekvenční pásmo: 2,4GHz - 2,4835GHz
- RF výkon: < 100 mW EIRP (ekvivalentní izotropně vyzářený výkon)

#### UPOZORNĚNÍ - ZÁRUKA

- Světelný zdroj obsažený v tomto svítidle nahrazují pouze výrobcem nebo jeho servisním zástupcem nebo podobně kvalifikovanou osobou.
- Toto svítidlo může být použito pouze k účelu, pro nějž bylo vyrobeno. Jakékoliv jiné použití bude považováno za nevhodné a tím také nebezpečné.
- Pro případné opravy se obraťte na autorizované servisní středisko, které používá pouze originální náhradní díly. Nerespektování výše uvedených podmínek může ohrozit bezpečnost zařízení.
- Tento výrobek obsahuje světelný zdroj s třídou energetické účinnosti D.
- \* **Upozornění:** úrazu elektrickým proudem

Firma Beghelli S.p.A. prohlašuje, že rádiové přijímací/vysílací zařízení je ve shodě se směrnicí 2014/53/EU. Kompletní text Prohlášení o shodě EU je dostupný na následující internetové adrese: [www.beghelli.it](http://www.beghelli.it)

Výše uvedené zařízení může být používáno v režimu „volného použití“.

#### KORZYSTANIE Z CZUJNIKA AUTOMATYCZNEGO PRZYCIEMIENIA (KOD. 15050-15051) (E)

**Ważne:** nie nakierowywać czujnika na zewnętrzne źródła światła. W przypadku systemu należy zwrócić uwagę na wybór urządzenia, na którym zamontujemy czujnik.

#### CHARAKTERYSTYKA TECHNICZNA RADIÓW

- Pasma częstotliwości: 2,4 GHz - 2,4835 GHz
- Moc sygnału RF: <100 mW EIRP

#### WARUNKI - GWARANCJA

- Źródłem światła zawarte w tej oprawy zostaje zastąpiony jedynie przez producenta lub jego przedstawiciela serwisu lub inną osobę wykwalifikowaną.
- Urządzenie powinno być stosowane wyłącznie do celów do jakich zostało zaprojektowane. Każde inne zastosowanie jest niewłaściwe a przez to i niebezpieczne.
- Proszę skontaktować się z działem serwisowym producenta przed przystąpieniem do naprawy. Zaleca się stosowanie oryginalnych części zamiennych. Nieprzestrzeganie powyższych zaleceń może być niebezpieczne.
- Ten produkt zawiera źródło światła o klasie efektywności energetycznej D.
- \* **Uwaga:** porażenie prądem

Beghelli S.p.A. oświadcza, że radiowe urządzenie nadawczo-odbiorcze jest zgodne z dyrektywą 2014/53/EU. Pełny tekst Deklaracji zgodności UE urządzenia można znaleźć na stronie internetowej [www.beghelli.it](http://www.beghelli.it)

Powyższe urządzenie można użytkować bez zezwolenia.